

WORKTOP FREEZER (0°F)

Model: SWF60NBS-D

Natural Refrigerant R-290 Model

60" Worktop Freezer with Drawers and 5½" Backsplash

Stainless steel front, top and end panels, aluminum back and interior.



Options and Accessories

(upcharge and lead times may apply)

Stainless steel interior	Drawer locks
Stainless steel back	Special electrical requirements (consult factory)
Overshelves (single or double)	
Adjustable legs	

Consult factory for other model configurations, options and accessories.

Project Name:

Model Specified:

Location:

Item No:

Quantity:

AIA #:

SIS #:

Standard Model Features

REFRIGERATION SYSTEM

Performance-rated refrigeration system

Natural, environmentally safe, high efficiency R-290 refrigerant¹

Automatic, hot gas condensate evaporator

Non-corrosive, plasticized fin evaporator coil

Easily serviceable, back mounted compressor

CABINET ARCHITECTURE

2" non-CFC polyurethane foam insulation

Smooth, polished chrome drawer handles

Stainless steel roll out drawers

Magnetic snap in Santoprene™ drawer gaskets

Completely enclosed, vented and removable case back

5" casters

MODEL FEATURES

Automatic electric defrost

Electronic controller with digital display & hi/low alarm

¹ R-290 refrigerant meets all federal and state regulatory requirements.

Continental
Refrigerator

Toll-Free: 800-523-7138
Phone: 215-244-1400
Fax: 215-244-9579

539 Dunksferry Road
Bensalem, PA 19020
www.continentalrefrigerator.com

APPROVAL:

Model Specifications

DIMENSIONAL DATA

Net Capacity (cubic feet)	17.0 (481 cu l)
Width, Overall (inches)	60 (1524 mm)
Depth, Overall (inches) (including handles & bumpers)	32 ³ / ₁₆ (818 mm)
Height, Overall (inches) (including 5" casters)	40 ³ / ₄ (1035 mm)
Number of Drawers (two tier)	4

REFRIGERANT DATA

Condensing Unit Size (H.P.)	1/2
Capacity (BTU per hour)*	2078

ELECTRICAL DATA

Voltage (International)	115/60/1 (220/50/1)
Total Amps (International)	7.8 (4.3)
Defrost Amps (International)	4.4 (2.5)
10 ft. Cord/Plug [attached] (International)	Yes (No)

SHIPPING DATA

Weight (pounds)	297 (135 kg)
Height - Crated (inches)	43 ¹ / ₄ (1099 mm)
Width - Crated (inches)	68 (1727 mm)
Depth - Crated (inches)	37 ¹ / ₄ (946 mm)

DRAWER PAN CONFIGURATIONS

Two Tier: (1) 12 x 20 x 6 pan per drawer

* Rating @ -15°F evaporator, 90°F ambient
Figures in parentheses reflect metric equivalents rounded to the nearest whole unit.



Equipped with one NEMA-5-15P Plug
(varies by country)

Model Plan Views

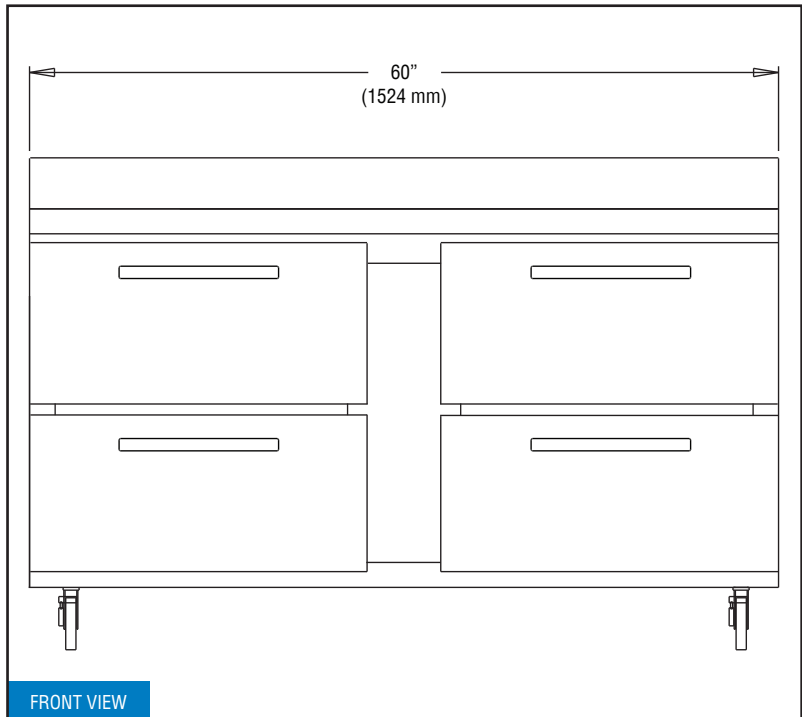

FRONT VIEW

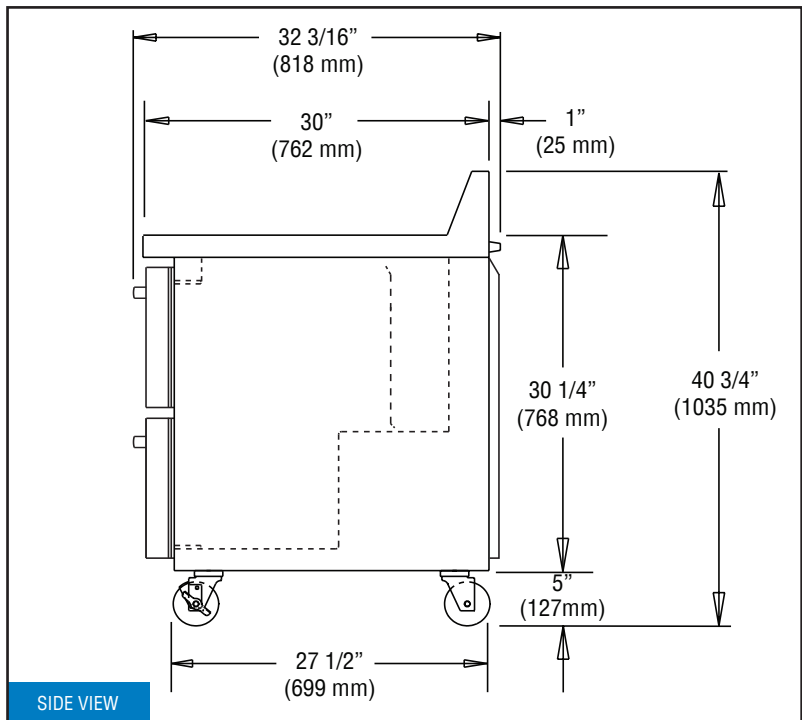

SIDE VIEW

IMPORTANT NOTE: If the cabinet is located directly against a wall, a minimum clearance of 3" is required on sides, front and rear.

Continental
Refrigerator

Toll-Free: 800-523-7138
Phone: 215-244-1400
Fax: 215-244-9579

539 Dunksferry Road
Bensalem, PA 19020
www.continentalrefrigerator.com

Due to our continued efforts in developing innovative products, specifications subject to change without notice.

